

CLEVELAND

MILLENNIUM

GEAR

DRIVES



Cleveland

CLEVELAND

MILLENNIUM

GEAR

DRIVES

Cleveland Millennium Gear Drives...are available in solid or hollow shaft models from 5" through 12" centers. Nominal ratios range between 5 x 1 and 60 x 1 allowable input. Horse powers exceed 200 with output torque ratings over 168,000 inch pounds. Units can be produced to meet almost any application requirements quickly because all model types are constructed from the same basic housing and feature adaptable mounting bases.

Why Cleveland?

Cleveland Millennium Gear Drives were developed to meet the demand for a compact, universal mount worm gear speed reducer. Produced in an atmosphere of thoroughness and accuracy at each step of design and production, Cleveland Millennium Gear Drives offer industry unmatched dependability. The many thousands of Cleveland drives providing faithful service throughout the world bear witness to the sound approach to worm gear engineering found in every Cleveland Millennium Gear Drive.

Design Features

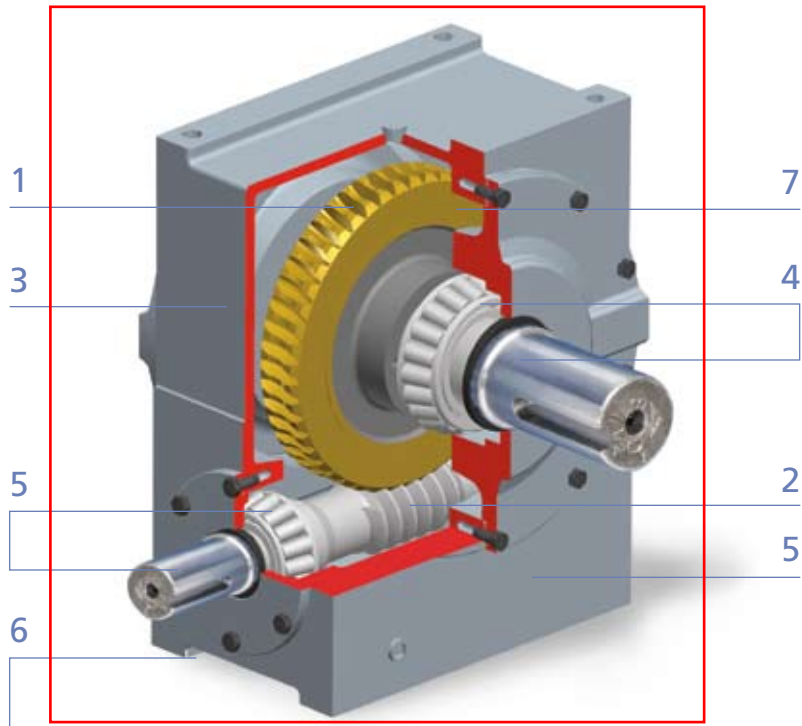

1. Bronze Gear Rims

Gear rims are cut from C907 cast bronze. This copper-tin alloy offers a relatively high hardness yet is ductile enough to avoid excessively high contact pressure and resist fatigue pitting. It affords low coefficient of friction while running against a hardened steel worm, insuring increased resistance to wear and maximum efficiency.

2. Flame-Hardened Worms

Cleveland Worms possess a high degree of hardness throughout the entire thread thickness and well below the worm's root diameter. This hardness pattern gives maximum thread strength and resistance to wear without sacrificing the advantages of a medium hard core.

3. Rugged Housings

Housings of highest quality cast iron provide maximum strength and heat dissipation. Cast iron housings also maintain accurate gear alignment.

4. Large Gear Shaft Diameters and Generously Sized Bearings

Worm and gear shafts are designed to withstand torsional and overhung loads. Generously sized bearings provide greater rigidity and are designed to accommodate radial, thrust and overhung loads.

5. Built-in Lubrication System

Cleveland Millennium units provide an engineered built-in lubrication system with an oil capacity more than adequate to lubricate the worm and gear. This additional oil capacity carries away heat from working contact surfaces and dissipates it through housing walls, increasing lubricant life. (This provides optimum cooling efficiency. As a result, oil oxidation rate is decreased).

6. Adaptable Mounting Feet

Adaptable mounting feet permit one basic housing to satisfy virtually any application requirement.

7. Unique Gear Rim and Center Fusion Bond Construction

The cast iron gear center and bronze rim in both solid and hollow shaft units are joined together by a fusion casting process. This method results in a rugged, one-piece construction.

Millennium Basic Units

Cleveland Millennium Gear Drives are available in solid and hollow output shaft arrangements. Adaptable mounting feet, made from heavy steel plate, can be used on either basic assembly. Both types offer a broad range of ratios and are available for quick delivery.

Mounting

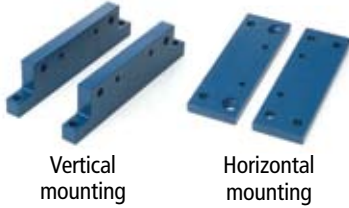

Vertical mounting

Horizontal mounting

Type 11



The Type 11 & 15 drives with solid output shaft assembly are available in four horizontal mounting arrangements and four vertical mounting arrangements. Any of these arrangements may be used for side or wall mounting. Arrangements requiring extended shafts are considered special and are made to order. The Type 15 design in size 50 – 80 is also available with motor flange adaptors to accept NEMA C motors. Ring base units, designed for vertical or side mounting directly on the machine or other structures, are also available in all sizes.

Type 12



Types 12 & 16 units are furnished with hollow output shafts. The design may be used as shaft mounts or shaft supports. They are available in the four basic mounting arrangements. Any of these basic arrangements may be used for side or wall mounting. Sizes 50-80 are also available with motor flange adaptors to accept NEMA C motors. In addition, the unit is available with a torque arm assembly. Base units, designed for vertical or side mounting directly on the machine or other structures, are also available.

Reducer Selection Procedure

1. Determine service factor from table below.
2. Calculate ratio required by dividing input shaft speed by output shaft speed.
3. Refer to rating tables. Select input or output rating which, when divided by the service factor, is equal to or greater than the load.
4. If either input or output shaft is connected by other than a flexible coupling, the overhung load must be calculated. Use the following formulas.

(a) Calculate speed reducer torque output:

$$\text{Actual Output Torque} = \frac{\text{Rated Output Torque}}{\text{Rated Input H.P.}} \times \text{Actual input H.P.}$$

(b) Calculate the actual overhung load (O.H.L.) for output/input:

$$\text{O.H.L.} = \frac{2 \times T \times F}{D}$$

Where: T = Actual output/input torque (in pounds)
D = Sprocket, sheave, etc., pitch diameter (inches)
F = O.H.L. factor

For overhung load capacities, see table below and rating tables on pages 5 and 6. If Actual O.H.L. exceeds rated O.H.L. capacity, refer to the next larger size unit.

Relationship between horsepower and input torque is shown by the two formulas below. For input speeds of 100 RPM or less, units are selected and rated on a torque basis.

$$\text{H.P.} = \frac{\text{Torque} \times \text{RPM}}{63,025} \quad \text{Torque (lb-in)} = \frac{63.025 \times \text{HP}}{\text{RPM}}$$

Application Data

Overhung Load Factors

Depending on the type of overhung load, the published overhung load figure should be divided by one of the following factors:

Overhung Member	Factor
Chain Sprocket	1.00
Spur Pinion	1.25
V-Belt Pulley	1.50
Flat Belt Pulley	2.00

Overhung load given in pounds at center of input shaft keyway.

Input Shaft Overhung Load Capacity

UNIT SIZE	WORM SHAFT CAPACITY	UNIT SIZE	WORM SHAFT CAPACITY
50	350	90	1,600
60	400	100	1,700
70	450	120	2,000
80	1,400		

Application Service Factor Table

DURATION OF SERVICE	LOAD NATURE											
	UNIFORM				MODERATE SHOCK				HEAVY SHOCK			
	Occasional 1/2 hour day	Intermittent 2 hours day	10 hours day	24 hours day	Occasional 1/2 hour day	Intermittent 2 hours day	10 hours day	24 hours day	Occasional 1/2 hour day	Intermittent 2 hours day	10 hours day	24 hours day
PRIME MOVER												
Electric Motor (Normal Service)	0.80	0.90	1.00	1.25	0.90	1.00	1.25	1.50	1.00	1.25	1.50	1.75
Multi-cylinder Internal Combustion Engine or Electric Motor (more than 10 starts per hour)	0.90	1.00	1.25	1.50	1.00	1.25	1.50	1.75	1.25	1.50	1.75	2.00
Single Cylinder Internal Combustion Engine	1.00	1.25	1.50	1.75	1.25	1.50	1.75	2.00	1.50	1.75	2.00	2.25

Ordering Code – Millennium Part Numbering Information

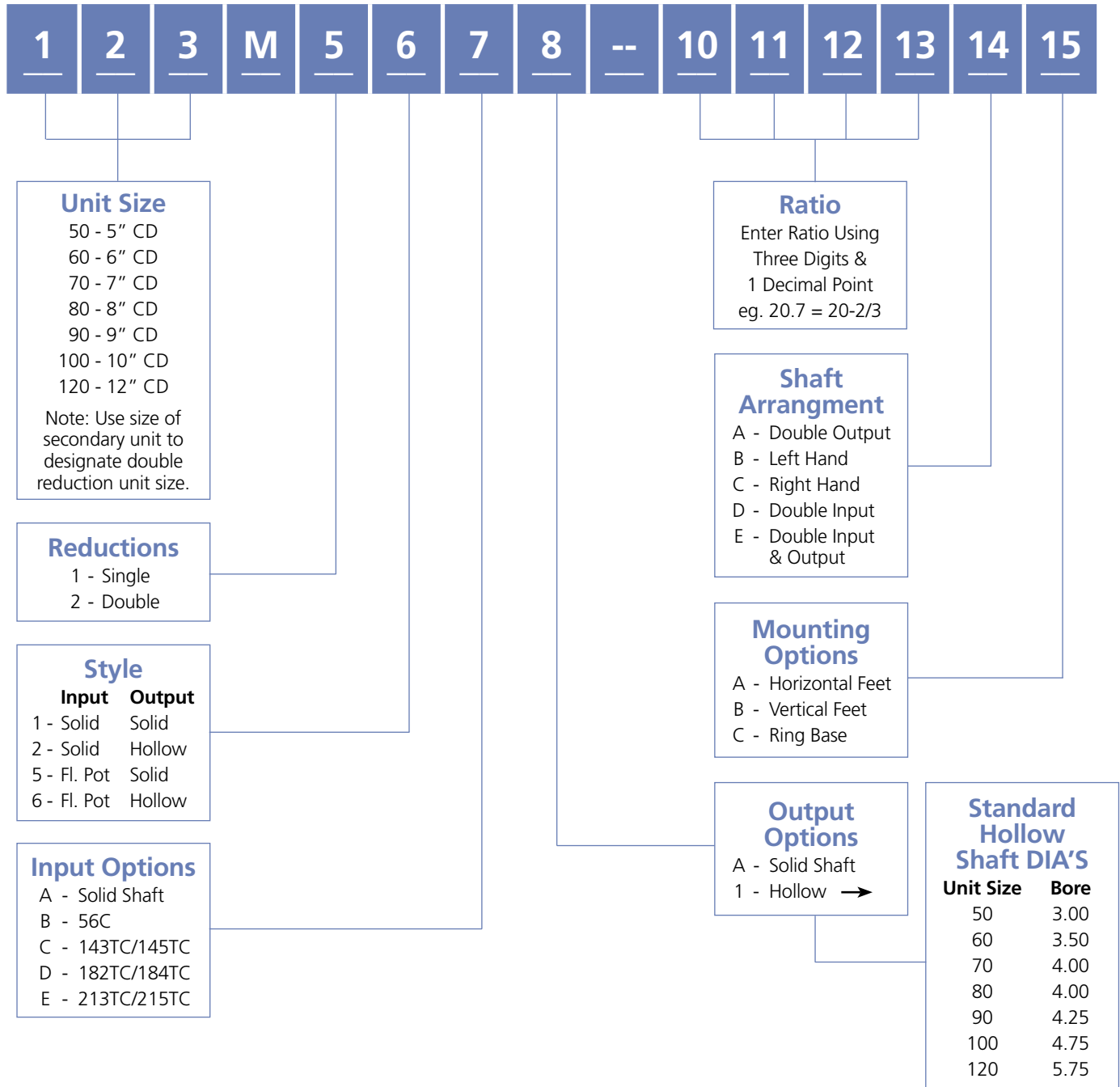

Diameters shown are maximum. Other bore diameters are available. Contact Factory.

Sample Part Numbers

50M11AA-10.7C

=

5"CD Solid Input, Solid Output
 10-2/3 : 1 Ratio, Right Hand Assembly

120M12A1-15.3BC

=

12"CD Solid Input, 5.25" Hollow Output,
 15-1/3 : 1 Ratio with Ring Base Mounted Left Hand Assembly

70M15CA-15.5BA

=

7"CD 143TC Motor Adapter, Solid Output,
 15-1/2 : 1 Ratio Left Hand Assembly with Horizontal Feet

Rating Tables

All ratings shown are based on A.G.M.A. standard 440.03 for a unity service factor. Stock ratios are listed in boldface type and should be ordered whenever possible for quickest delivery. Additional ratios may be available and units will be built to order.

Output torque ratings shown are given in inch pounds. Overhung loads shown are given in pounds at center of output shaft keyway.

		RATIO	1750 RPM	1150 RPM	870 RPM	100 RPM		RATIO	1750 RPM	1150 RPM	870 RPM	100 RPM
SIZE 50 Single Reduction Worm Gear 5.000" Centers	4 5/6	Input H.P.	32.72	27.08	24.15	4.48	25	Input H.P.	8.7	7.27	6.56	1.33
		Output Torque	5513	6914	8125	12659		Output Torque	6937	8682	10236	16099
		Overhung Load	1211	1211	1211	1211		Overhung Load	1211	1211	1211	1211
	7 2/5	Input H.P.	23.68	19.64	17.32	3.28	30	Input H.P.	7.34	6.18	5.5	1.09
		Output Torque	6046	7586	9010	13851		Output Torque	6944	8752	10172	15382
		Overhung Load	1211	1211	1211	1211		Overhung Load	1211	1211	1211	1211
	10 2/3	Input H.P.	17.86	14.8	13.28	2.55	40	Input H.P.	5.72	4.82	4.35	0.92
		Output Torque	6469	8097	9547	15015		Output Torque	6862	8613	10106	15688
		Overhung Load	1211	1211	1211	1211		Overhung Load	1211	1211	1211	1211
	14 1/3	Input H.P.	14.01	11.72	10.31	1.89	56	Input H.P.	4.04	3.44	3.08	0.65
		Output Torque	6753	8522	9844	14634		Output Torque	6469	8159	9456	14189
		Overhung Load	1211	1211	1211	1211		Overhung Load	1211	1211	1211	0
20	Input H.P.	10.58	8.83	7.92	1.56	64	Input H.P.	3.4	2.91	2.58	0.54	
	Output Torque	6909	8665	10181	15864		Output Torque	6124	7732	8885	13023	
	Overhung Load	1211	1211	1211	1211		Overhung Load	1211	1211	1211	1211	
SIZE 60 Single Reduction Worm Gear 6.000" Centers	5 1/3	Input H.P.	45.53	38.19	33.71	6.92	24 1/2	Input H.P.	13.1	10.81	9.86	2.04
		Output Torque	8459	10750	12504	21534		Output Torque	10416	12910	15417	25111
		Overhung Load	1750	1750	1750	1750		Overhung Load	1750	1750	1750	1750
	7 2/5	Input H.P.	35.46	28.77	26.34	5.28	30	Input H.P.	10.92	9.04	8.25	1.74
		Output Torque	9079	11152	13442	22466		Output Torque	10421	12930	15422	25036
		Overhung Load	1750	1750	1750	1750		Overhung Load	1750	1750	1750	1750
	11	Input H.P.	25.97	21.36	19.32	3.78	40	Input H.P.	8.48	6.98	6.47	1.46
		Output Torque	9760	12137	14437	23267		Output Torque	10305	12649	15422	25536
		Overhung Load	1750	1750	1750	1750		Overhung Load	1750	1750	1750	1750
	14 2/3	Input H.P.	20.73	17.47	15.5	3.25	50	Input H.P.	6.91	5.92	5.32	1.25
		Output Torque	10177	12934	15062	25481		Output Torque	9996	12704	14794	25028
		Overhung Load	1750	1750	1750	1750		Overhung Load	1750	1750	1750	1750
20	Input H.P.	15.81	12.91	11.88	2.51	60	Input H.P.	5.53	4.64	4.27	0.97	
	Output Torque	10376	12737	15361	25712		Output Torque	9482	11771	14031	22742	
	Overhung Load	1750	1750	1750	1750		Overhung Load	1750	1750	1750	1750	
SIZE 70 Single Reduction Worm Gear 7.000" Centers	5 1/3	Input H.P.	64.08	53.73	47.12	10.14	25	Input H.P.	18.14	15.36	13.61	3.07
		Output Torque	11936	15170	17532	31781		Output Torque	14690	18570	21663	38226
		Overhung Load	2002	2002	2002	2002		Overhung Load	2002	2002	2002	2002
	7	Input H.P.	52.06	43.68	38.39	8.23	30	Input H.P.	15.27	12.94	11.5	2.57
		Output Torque	12656	16085	18620	33410		Output Torque	14683	18661	21689	37691
		Overhung Load	2002	2002	2002	2002		Overhung Load	2002	2002	2002	2002
	10 1/4	Input H.P.	38.78	32.6	28.52	6.41	40	Input H.P.	11.79	10.04	8.96	2.06
		Output Torque	13611	17298	19907	36910		Output Torque	14500	18428	21431	36989
		Overhung Load	2002	2002	2002	2002		Overhung Load	2002	2002	2002	2002
	15 1/2	Input H.P.	27.81	23.43	20.59	4.64	51	Input H.P.	9.26	7.91	7.07	1.7
		Output Torque	14495	18422	21259	38854		Output Torque	14027	17827	20696	36358
		Overhung Load	2002	2002	2002	2002		Overhung Load	2002	2002	2002	2002
19	Input H.P.	23.25	19.63	17.31	3.91	61	Input H.P.	7.5	6.43	5.77	1.35	
	Output Torque	14630	18593	21505	38792		Output Torque	13230	16814	19583	32976	
	Overhung Load	2002	2002	2002	2002		Overhung Load	2002	2002	2002	2002	
SIZE 80 Single Reduction Worm Gear 8.000" Centers	5 1/8	Input H.P.	88.76	74.41	64.41	14.68	24	Input H.P.	25.14	21.25	18.59	4.43
		Output Torque	15926	20240	23096	44420		Output Torque	19755	25107	28788	54283
		Overhung Load	2740	3010	3220	4575		Overhung Load	4490	4757	4757	4757
	7 1/5	Input H.P.	68.59	57.55	51.24	11.76	31	Input H.P.	20.04	17	14.75	3.76
		Output Torque	17144	21789	25552	49049		Output Torque	19794	25156	28533	56110
		Overhung Load	3030	3330	3530	4757		Overhung Load	4757	4757	4757	4757
	10 1/3	Input H.P.	51.73	43.47	37.47	8.9	41	Input H.P.	15.54	13.24	11.59	2.98
		Output Torque	18360	23334	26465	52045		Output Torque	19515	24802	28301	54431
		Overhung Load	3360	3690	3960	4757		Overhung Load	4757	4757	4757	4757
	15 1/2	Input H.P.	37.17	31.3	27.02	6.53	51	Input H.P.	12.38	10.57	9.35	2.37
		Output Torque	19440	24707	28023	55108		Output Torque	18866	23977	27559	51393
		Overhung Load	3765	4130	4420	4757		Overhung Load	4757	4757	4757	4757
19 1/2	Input H.P.	30.52	25.77	23.04	5.52	60	Input H.P.	10.41	8.93	7.89	2.08	
	Output Torque	19711	25052	29378	56227		Output Torque	17997	22872	26212	49534	
	Overhung Load	4175	4600	4570	4757		Overhung Load	4757	4757	4757	4757	

Rating Tables

All ratings shown are based on A.G.M.A. standard 440.03 for a unity service factor. Stock ratios are listed in boldface type and should be ordered whenever possible for quickest delivery. Additional ratios may be available and units will be built to order.

Output torque ratings shown are given in inch pounds. Overhung loads shown are given in pounds at center of output shaft keyway.

			1750 RPM	1150 RPM	870 RPM	100 RPM		1750 RPM	1150 RPM	870 RPM	100 RPM	
SIZE 90 Single Reduction Worm Gear 9.000" Centers	5 1/8	Input H.P.	114.64	96.07	82.94	19.04	24	Input H.P.	32.62	27.57	24.67	6.11
		Output Torque	20608	26191	29812	57887		Output Torque	25696	32658	38298	75151
		Overhung Load	5504	5504	5504	5504		Overhung Load	5504	5504	5504	5504
	7 2/5	Input H.P.	87.14	73.12	65.09	15.68	31	Input H.P.	25.99	22.03	19.76	5.16
		Output Torque	22416	28489	33409	67414		Output Torque	25736	32708	38357	77581
		Overhung Load	5504	5504	5504	5504		Overhung Load	5504	5504	5504	5504
	10	Input H.P.	68.77	57.76	51.45	12.19	40	Input H.P.	20.17	17.13	14.95	3.79
		Output Torque	23719	30144	35351	69613		Output Torque	25298	32151	36630	70874
		Overhung Load	5504	5504	5504	5504		Overhung Load	5504	5504	5504	5504
	15 1/2	Input H.P.	48.25	40.63	36.26	9	51	Input H.P.	15.98	13.64	12.29	3.26
		Output Torque	25276	32124	37672	76195		Output Torque	24554	31206	36596	71683
		Overhung Load	5504	5504	5504	5504		Overhung Load	5504	5504	5504	5504
	20	Input H.P.	38.48	32.47	29.02	7.25	62	Input H.P.	12.85	11.01	9.95	2.69
		Output Torque	25616	32556	38179	76614		Output Torque	23075	29326	34391	66935
		Overhung Load	5504	5504	5504	5504		Overhung Load	5504	5504	5504	5504
SIZE 100 Single Reduction Worm Gear 10.000" Centers	4 5/6	Input H.P.	148.02	124.06	110.35	27.71	24	Input H.P.	40.73	34.39	30.75	7.6
		Output Torque	25078	31872	37377	79336		Output Torque	32334	41094	48192	95050
		Overhung Load	7701	7701	7701	7701		Overhung Load	7701	7701	7701	7701
	7 2/5	Input H.P.	109.84	92.13	82	20.11	30 1/2	Input H.P.	32.86	27.81	24.92	6.45
		Output Torque	28320	35992	42209	86947		Output Torque	32484	41284	48415	98286
		Overhung Load	7701	7701	7701	7701		Overhung Load	7701	7701	7701	7701
	10	Input H.P.	84.48	70.95	63.21	16.15	39	Input H.P.	26.56	22.58	20.3	5.59
		Output Torque	29127	37018	43411	92135		Output Torque	32229	40961	48035	100229
		Overhung Load	7701	7701	7701	7701		Overhung Load	7701	7701	7701	7701
	15	Input H.P.	62.49	52.59	46.91	11.82	49	Input H.P.	20.99	17.89	16.11	4.47
		Output Torque	31830	40453	47440	97820		Output Torque	31311	39793	46666	96336
		Overhung Load	7701	7701	7701	7701		Overhung Load	7701	7701	7701	7701
	20	Input H.P.	48.05	40.5	36.17	8.83	58	Input H.P.	17.32	14.8	13.35	3.65
		Output Torque	32201	40925	47993	94662		Output Torque	29877	37971	44529	89020
		Overhung Load	7701	7701	7701	7701		Overhung Load	7701	7701	7701	7701
SIZE 120 Single Reduction Worm Gear 12.000" Centers	5 1/3	Input H.P.	211.57	177.28	157.66	41.43	25	Input H.P.	58.88	49.71	44.45	12.17
		Output Torque	39617	50350	59047	131366		Output Torque	48701	61895	72585	158722
		Overhung Load	12229	12229	12229	12229		Overhung Load	12229	12229	12229	12229
	7 2/5	Input H.P.	164.5	137.94	122.75	32.45	30	Input H.P.	49.91	42.22	37.81	10.54
		Output Torque	42494	54007	63335	140896		Output Torque	48745	61951	72651	159420
		Overhung Load	12229	12229	12229	12229		Overhung Load	12229	12229	12229	12229
	10	Input H.P.	129.92	109.06	97.12	25.89	40	Input H.P.	38.37	32.59	29.27	8.56
		Output Torque	44998	57189	67066	149193		Output Torque	48246	61316	71906	160631
		Overhung Load	12229	12229	12229	12229		Overhung Load	12229	12229	12229	12229
	15 1/3	Input H.P.	91.46	76.93	68.61	18.36	50	Input H.P.	30.45	25.94	23.34	6.81
		Output Torque	47804	60754	71248	156587		Output Torque	46706	59360	69612	152221
		Overhung Load	12229	12229	12229	12229		Overhung Load	12229	12229	12229	12229
	20	Input H.P.	72.47	61.08	54.56	15.08	59	Input H.P.	25.04	21.37	19.26	5.57
		Output Torque	48578	61739	72402	161738		Output Torque	44465	56511	66271	141702
		Overhung Load	12229	12229	12229	12229		Overhung Load	12229	12229	12229	12229

Dimensions/Type 11

Millennium Unit SIZES 50-120

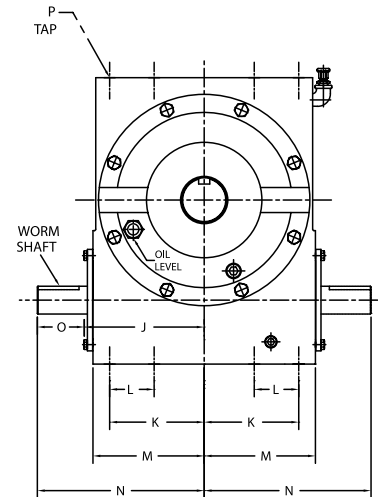
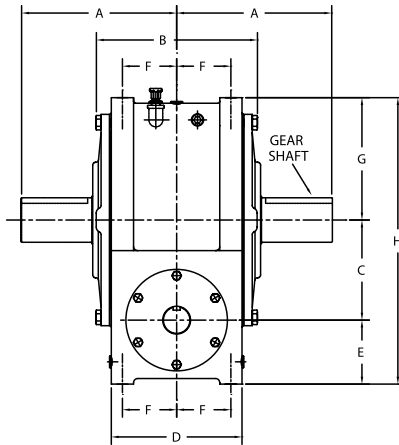

TYPE 11 - BASIC UNIT DIMENSIONS

UNIT SIZE	A	B	C +0.03 -0.00	D	E +0.00 -0.03	F	G +0.00 -0.03	H	J	K	L	M	N	O
50M	7.50	7.00	5.000	5.75	3.38	2.19	5.75	14.12	6.31	4.38	-	5.62	8.75	2.44
60M	10.00	9.50	6.000	7.75	4.25	2.88	6.75	17.00	7.56	5.62	-	6.88	11.50	3.94
70M	11.00	10.25	7.000	8.00	4.50	3.00	8.50	20.00	8.56	6.50	-	7.88	12.50	3.94
80M	13.50	12.94	8.000	10.75	5.50	4.50	9.50	23.00	9.55	7.38	-	8.75	13.50	3.95
90M	14.75	14.53	9.000	12.00	5.75	4.88	11.00	25.75	10.81	8.50	4.00	10.00	15.00	4.19
100M	15.75	15.53	10.000	13.00	6.00	5.13	12.00	28.00	11.98	9.25	5.00	11.00	16.50	4.19
120M	19.25	19.30	12.000	17.00	7.00	7.13	14.00	33.00	14.47	11.00	5.00	13.25	20.50	6.03

UNIT SIZE	P Tap	Worm Shaft		Gear Shaft		Net Wt. (lbs)
		Diameter	Key Size	Diameter	Key Size (in.)	
50M	1/2-13 x 1	1.375 +0.000 -0.001	5/16 x 5/16 x 1 7/8	2.000 +0.000 -0.001	1/2 x 1/2 x 2 3/4	152
60M	5/8-11 x 1 1/4	1.500 +0.000 -0.001	3/8 x 3/8 x 2 3/4	2.500 +0.000 -0.001	5/8 x 5/8 x 3 3/4	288
70M	5/8-11 x 1 1/4	1.625 +0.000 -0.001	3/8 x 3/8 x 2 3/4	2.750 +0.000 -0.001	5/8 x 5/8 x 4	395
80M	1"-8 X 2	2.250 +0.000 -0.001	1/2 x 1/2 x 3 5/8	3.750 +0.000 -0.001	7/8 x 7/8 x 6	760
90M	1"-8 X 2	2.500 +0.000 -0.001	5/8 x 5/8 x 3 3/4	4.000 +0.000 -0.001	1 x 1 x 6	800
100M	1"-8 X 2	2.625 +0.000 -0.001	5/8 x 5/8 x 3 3/4	4.500 +0.000 -0.001	1 x 1 x 6	1000
120M	1 1/4-7 X 2 1/2	3.000 +0.000 -0.001	3/4 X 3/4 X 4 3/4	5.250 +0.000 -0.001	1 1/4 X 1 1/4 X 7 1/4	1550

Dimensions/Type 12

Millennium Unit SIZES 50-120

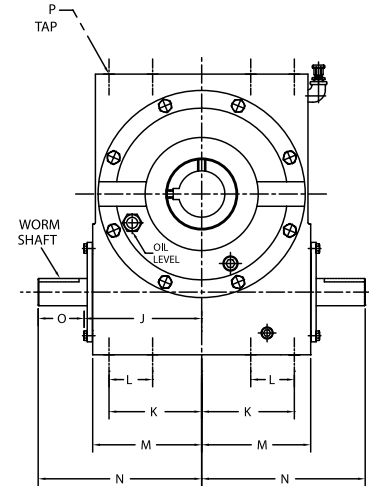
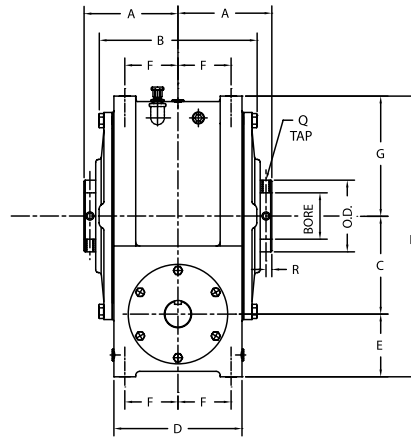

TYPE 12 - BASIC UNIT DIMENSIONS

UNIT SIZE	A	B	C +.003 -.000	D	E +.00 -.03	F	G +.00 -.03	H	J	K	L	M	N	O
50M	4.25	7.00	5.000	5.75	3.38	2.19	5.75	14.12	6.31	4.38	-	5.62	8.75	2.44
60M	5.75	9.50	6.000	7.75	4.25	2.88	6.75	17.00	7.56	5.62	-	6.88	11.50	3.94
70M	6.00	10.25	7.000	8.00	4.50	3.00	8.50	20.00	8.56	6.50	-	7.88	12.50	3.94
80M	8.00	12.94	8.000	10.75	5.50	4.50	9.50	23.00	9.55	7.38	-	8.75	13.50	3.95
90M	8.50	14.53	9.000	12.00	5.75	4.88	11.00	25.75	10.81	8.50	4.00	10.00	15.00	4.19
100M	9.25	15.53	10.000	13.00	6.00	5.13	12.00	28.00	11.98	9.25	5.00	11.00	16.50	4.52
120M	11.25	19.30	12.000	17.00	7.00	7.13	14.00	33.00	14.47	11.00	5.00	13.25	20.50	6.03

UNIT SIZE	P Tap	Worm Shaft		Q Tap	R	Hollow Gear Shaft			Net Wt. (lbs)
		Diameter	Key Size			Bore +.002 -.000	O.D.	Shaft Keyseat Required (in.)	
50M	1/2-13 x 1	1.375 +.000 -.001	5/16 x 5/16 x 1 7/8	3/8-16	0.38	3.000	4.25	3/4 x 3/8 x 2 3/4	152
60M	5/8-11 x 1 1/4	1.500 +.000 -.001	3/8 x 3/8 x 2 3/4	1/2-13	0.50	3.500	5.00	7/8 x 7/16 x 3 1/2	288
70M	5/8-11 x 1 1/4	1.625 +.000 -.001	3/8 x 3/8 x 2 3/4	1/2-13	0.50	4.000	5.75	1 x 1/2 x 4	395
80M	1"-8 X 2	2.250 +.000 -.001	1/2 x 1/2 x 3 5/8	1/2-13	0.5	4.000	5.63	1 x 1/2 x 6 3/4	760
90M	1"-8 X 2	2.500 +.000 -.001	5/8 x 5/8 x 3 3/4	1/2-13	0.5	4.250	5.75	1 x 1 x 7	800
100M	1"-8 X 2	2.625 +.000 -.001	5/8 x 5/8 x 3 3/4	3/4-10	0.75	4.750	6.50	1 x 1 x 7	1000
120M	1 1/4-7 X 2 1/2	3.000 +.000 -.001	3/4 X 3/4 X 4 3/4	1"-8	1.00	5.750	7.75	1 1/4 x 1 1/4 x 8 1/2	1550

Dimensions/Type 11 or 12

Horizontal Mounting Arrangements

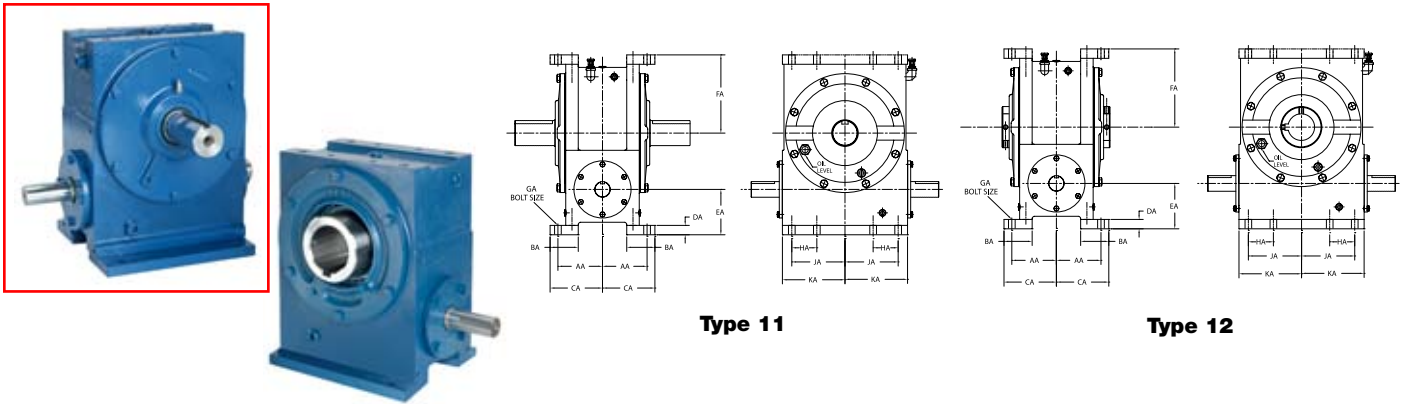

TYPE 11 or 12 - HORIZONTAL MOUNTING ARRANGEMENTS

UNIT SIZE	AA	BA	CA	DA	EA +0.00 -0.03	FA +0.00 -0.03	GA Bolt Size (in.)	HA	JA	KA
50M	3.88	3.00	4.38	0.62	4.00	6.38	1/2	-	4.38	5.50
60M	5.25	4.00	6.00	0.75	5.00	7.50	5/8	-	5.62	6.75
70M	5.75	4.50	6.50	0.75	5.25	9.25	5/8	-	6.50	7.75
80M	6.62	4.25	7.88	1.50	7.00	11.00	1	-	7.75	8.75
90M	7.13	4.50	8.38	1.50	7.25	12.50	1	4.00	8.50	10.00
100M	7.62	5.00	8.88	1.50	7.50	13.50	1	4.00	9.25	11.00
120M	9.75	5.25	11.25	2.00	9.00	16.00	1 1/4	5.00	11.00	13.25

Dimensions/Type 11 or 12

Vertical Mounting Arrangements

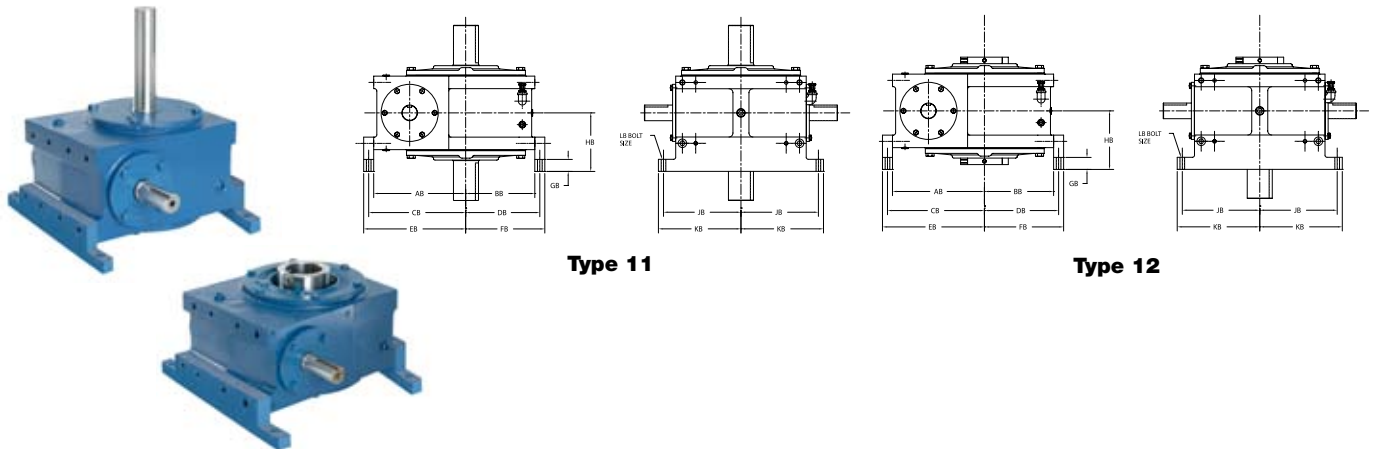

TYPE 11 or 12 - VERTICAL MOUNTING ARRANGEMENTS

UNIT SIZE	AB	BB	CB	DB	EB	FB	GB	HB +0.00 -0.03	JB	KB	LB Bolt Size (in.)
50M	8.38	5.75	8.88	6.25	9.38	6.75	1.00	4.38	6.88	7.50	1/2
60M	10.25	6.75	10.88	7.38	11.50	8.00	1.25	6.00	8.50	9.25	5/8
70M	11.50	8.50	12.12	9.12	12.75	9.75	1.25	6.50	9.50	10.25	5/8
80M	13.50	9.50	14.50	10.50	15.50	11.50	2.00	9.00	10.25	11.50	1
90M	14.75	11.00	15.75	12.00	16.75	13.00	2.00	9.50	11.50	12.75	1
100M	16.00	12.00	17.00	13.00	18.00	14.00	2.00	10.50	12.50	13.75	1
120M	19.00	14.00	20.25	15.25	21.50	16.50	2.50	13.00	14.50	16.25	1 1/4

Dimensions/Type 15 or 16

Motor Adapter

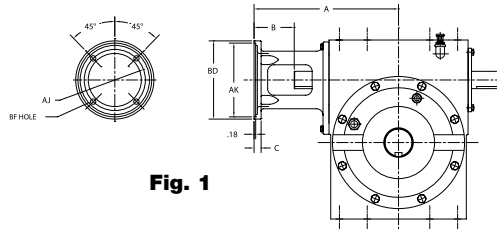

Fig. 1

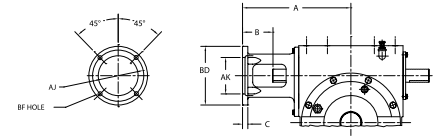

Fig. 2

TYPES 15 & 16 - MOTOR ADAPTER

UNIT SIZE	Motor Frame NEMA C Face Mounting		Mounting Face				A	B	C	Cplg. Max. O.D.
	FIG 1	FIG 2	AJ	AK +.002 -.000	BD	BF				
50M		143TC 145TC	5.88	4.501	6.62	13/32	11.00	2.25	0.50	4.45
		182TC 184TC 213TC 215TC 254TC 256TC	7.25	8.501	9.00	17/32	12.56	3.81	0.94	5.00
		182TC 184TC 213TC 215TC 254TC 256TC	7.25	8.501	9.00	17/32	15.31	3.81	0.81	5.45
60M		284TC 286TC 324TC 326TC	9.00 11.00	10.501 12.501	11.25 13.25	17/32 21/32	16.00 16.62	4.50 5.12	1.06 1.12	6.35 7.50
		182TC 184TC 213TC 215TC 254TC 256TC	7.25	8.501	9.00	17/32	16.31	3.81	0.81	5.45
		284TC 286TC 324TC 326TC	9.00 11.00	10.501 12.501	11.25 13.25	17/32 21/32	17.00 17.62	4.50 5.12	1.06 1.12	6.35 7.50

Dimensions/Type 11 or 12

Ring Base Mount

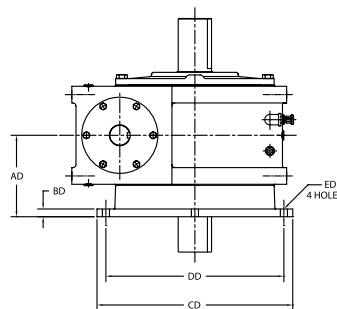

Type 11

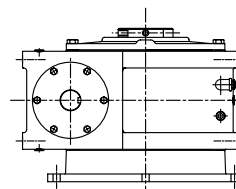

Type 12

TYPES 11 & 12 - RING BASE MOUNT

UNIT SIZE	A ₀ +.00 -.03	B ₀	C ₀	D ₀	E ₀ Hole
50M	5.63	0.75	15.50	14.00	11/16
60M	7.25	0.75	18.00	15.63	11/16
70M	7.44	0.75	21.00	18.38	25/32
80M	8.34	0.75	24.00	21.00	1 1/32
90M	9.00	1.00	27.00	23.50	1 1/32
100M	9.06	1.00	29.00	25.00	1 1/32
120M	12.25	1.00	32.00	29.00	1 1/32

Cleveland Gear's Library of Information

"MUST" For Your Engineering Department



▶ **Catalog #900 – Capabilities Brochure**
Summarizes Cleveland's capabilities and 90+ year tradition of gear flexibility, innovation, reliability and service.

▶ **Catalog #500 – Fan-Cooled Speed Reducers**
Extensive data on selection, installation and maintenance, including design features, ratings and dimensions on all three types.

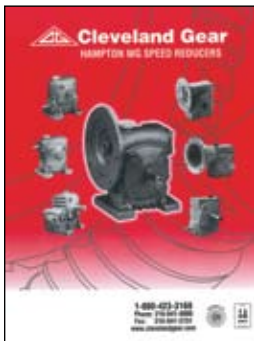
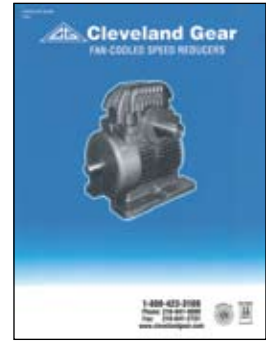

▶ **Catalog #800 – Hampton WG Speed Reducers**
Provides horsepower, torque ratings, dimensional data and part/maintenance information on Single and Double Reduction Speed Reducers.

▶ **Catalog #600 – Open Gearing**
Includes application classifications and service factor tables, plus, ratings tables, special designs, and worm and gear dimensions.

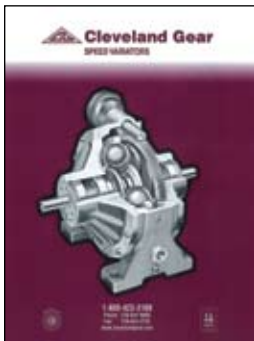
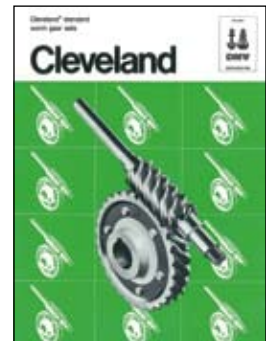

▶ **Catalog #200 – Speed Variators**
Includes detailed data on features, applications and selection procedures for Cleveland's ball-type, mechanical, and variable speed drives.

▶ **Catalog #300 – Redi II Enclosed Drives**
Comprehensive reference with selection guide and rating tables – for single through quadruple reduction, helical and bevel helical speed reducers.

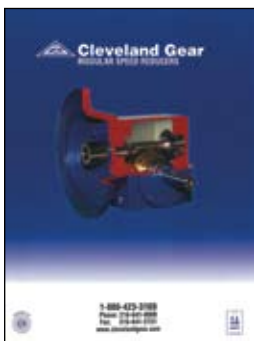

▶ **Catalog #400 – Modular Speed Reducers**
Extensive data on design features and selections for both single and double reduction drives.

Call Toll-Free: 1-800-423-3169



CLEVELAND Gear Co.

3249 EAST 80th STREET
CLEVELAND, OH 44104

800-423-3169

www.clevelandgear.com